

> **DM4.0T/SB2 230V**  
> **DM4.0T/SB2 400V**

WWW.DAMARL.COM



**ELEVADOR 2 COLUMNAS**  
SIN BASE

- Estructura de portería sin base inferior
- 2 Cilindros hidráulicos + cadena
- Sincronización mediante cable de acero
- Electroválvula de bajada
- Sistema de bloqueo de seguridad electromagnético
- Micros electrónicos de final de carrera y altura
- Brazos largos de 3 tramos
- Realzas incluidas

**2 POST LIFT**  
BASELESS LIFT

- Floor installation
- 2 Cylinder & chain drive
- Synchronization steel rope
- Electromagnetic lowering valve
- Electrical lock release
- Electrical safety devices for balancing cables and maximum height
- Three-stage long arms
- Extensions included

**PONT ÉLEVATEUR À 2 COLONNES**  
SANS EMBASE

- Structure porteuse sans base inférieure
- 2 vérins hydrauliques + chaîne
- Synchronisation par câble acier
- Electrovanne de descente
- Système de verrouillage électromagnétique de sécurité
- Micros contact électroniques pour fin de course et hauteur
- Bras longs à 3 sections
- Réhausses incluses

**4000 KG**



- 4000 KG
- 90 - 1890 mm
- 4050 mm
- 3420 mm
- ≤ 45 s
- ≤ 45 s
- 2.2 KW
- 400V/3ph/50Hz  
230V/1ph/50Hz
- 673 KG

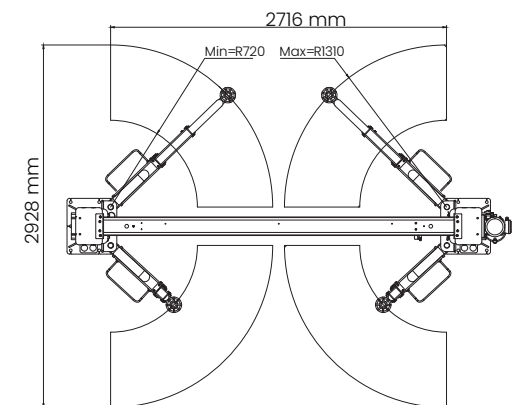
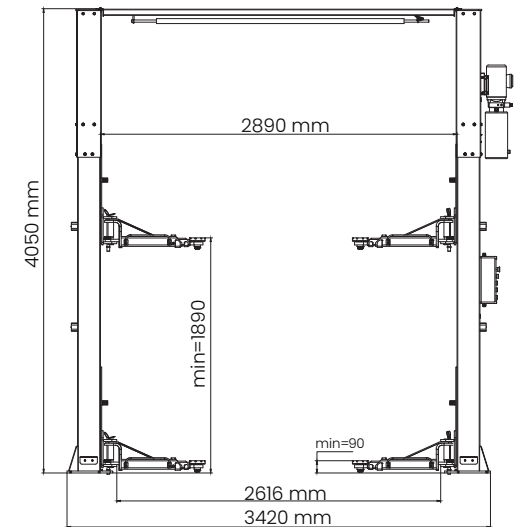

INCLUIDO - INCLUDED - INCLUS



4 UDS x Ø 115 mm



4 UDS x 70 mm  
4 UDS x 100 mm



**SCAN ME!**

**ES:** Escanea el código para mas información

**FR:** Scanner le code pour plus d'informations

**EN:** Scan the code for more information

