

ELEVADOR TIJERA
ELECTROHIDRÁULICO

Mesa elevadora para instalación de baterías de vehículos electricos, motores, transmisiones, suspensiones

SCISSOR LIFT
ELECTRO-HYDRAULIC

Ideal for electric car battery replacement, aswell as heavy duty gearboxes, engines, etc

PONT ÉLÉVATEUR À CISEAUX
ÉLECTROHYDRAULIQUE

Table élévatrice pour remplacement de batteries de véhicules électriques, moteurs, transmissions, suspensions

1200 KG



- 1200 KG
- 570 - 1920 mm
- 1590 mm
- 0,75 KW
- 230V/1ph/50Hz
- 390 KG

OPCIONAL - OPTIONAL - OPTIONNEL

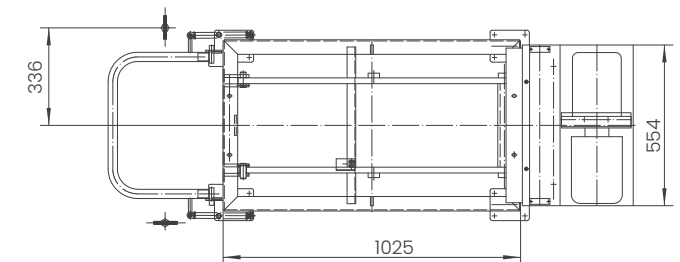
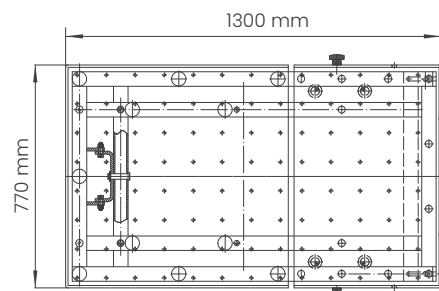
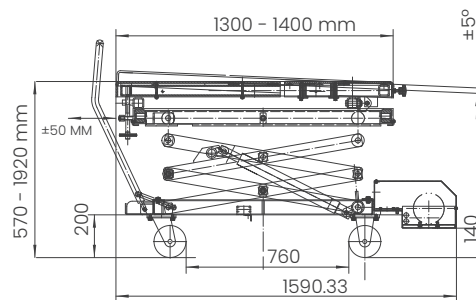
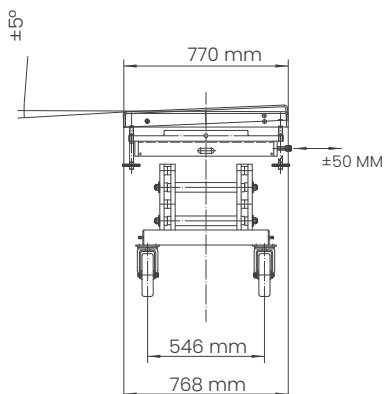

SCAN ME!

ES: Escanea el código para mas información
FR: Scanner le code pour plus d'informations
EN: Scan the code for more information

